

Flange Seal XSFL07

Function:

The flange seal *XSFL07* is a symmetric, spring energized seal for axial sealing applications. The geometry is leant against profile *XSPRS19C*.

Features:

- Especially designed for pressure from inside.
- Preload effected through Helicoil-spring which ensures high pressure on the sealing lips.
- Excellent static and dynamic sealing performance.
- Excellent sealing performance in low and high pressure ranges.
- Wide application ranges – especially suitable for gas and vacuum applications.
- Simple mounting.
- Compact and simple grooves.

Application:

Static sealing (e.g. flanges), chemical industry, Oil&Gas, aviation, rotary joints

NOTE: The inside diameter is limited to about 15 mm minimum. The cross section should not exceed 10 mm. For dimensions out of the limits production from 2 sides or special tools might be necessary!

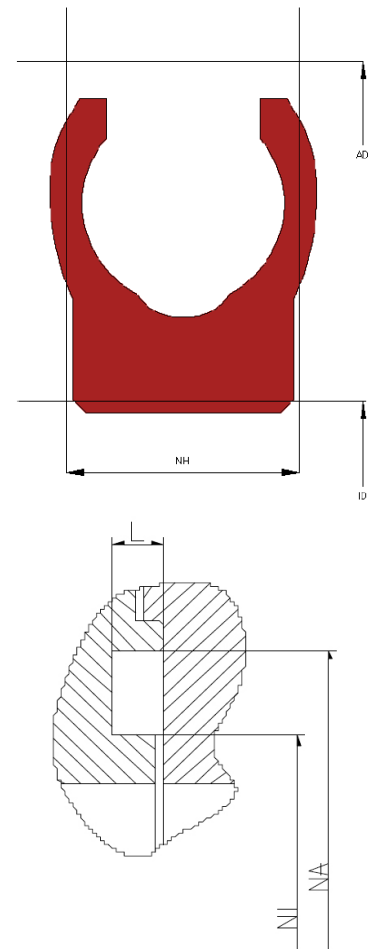

Seal housing recommendation:

Tolerances	[mm]	
L	+0.2	
Ø NA	H 8	
Ø NI	f 8	

Surface roughness	Rtmax [μ]	Ra [μ]
Bottom of groove	≤ 6.3	≤ 1.6
Face of groove	≤ 15	≤ 3

Sliding surface	Rtmax [μ]	Ra [μ]
PU, elastomeres	≤ 2.5	$\leq 0.1 - 0.5$
PTFE	≤ 2	$\leq 0.05 - 0.3$

Installation:

Snap-in installation.