

Piston Seal XSPS01

Function:

Piston seals are designed to seal the pressurized hydraulic fluid against the atmosphere or between two pressurized spaces.

Features:

- Asymmetrical, single acting piston seal, designed with interference on the ID which provides a good static fit in the groove.
- Dynamic sealing lip shorter than static lip to avoid drag pressure.
- Excellent static and dynamic sealing performance.
- Useable for long stroke lengths.
- Negligible tendency to “stick-slip” effect above a speed of 0.15 m/s. For lower speeds the dynamic lip should be redesigned (shorter, stiffer).

Application:

Reciprocating pistons in hydraulic cylinders, plungers.
Universal piston seal for small extrusion gaps and minor load impacts.
Max. pressure 400 bar, max. speed 0.5 m/s.

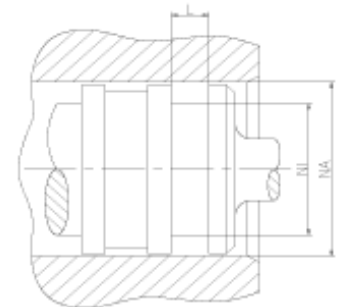
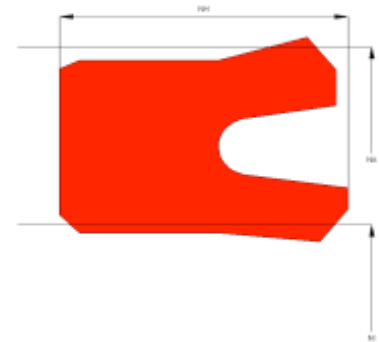

Seal housing recommendation:

Tolerances	[mm]	
L < 10mm	+0.2	
L ≥ 10mm	+0.3	
Ø NA	H9	
Ø NI	h10	

Surface roughness	Rtmax [μ]	Ra [μ]
Bottom of groove	≤ 6.3	≤ 1.6
Face of groove	≤ 15	≤ 3

Sliding surface	Rtmax [μ]	Ra [μ]
PU, elastomeres	≤ 2.5	≤ 0.1 - 0.5
PTFE	≤ 2	≤ 0.05 - 0.3

Installation:

Snap-in installation